

LUXE WARDROBE AUTOMATION, INC
INSTALLATION OPTIONS

CEILING MOUNT INSTALLATION

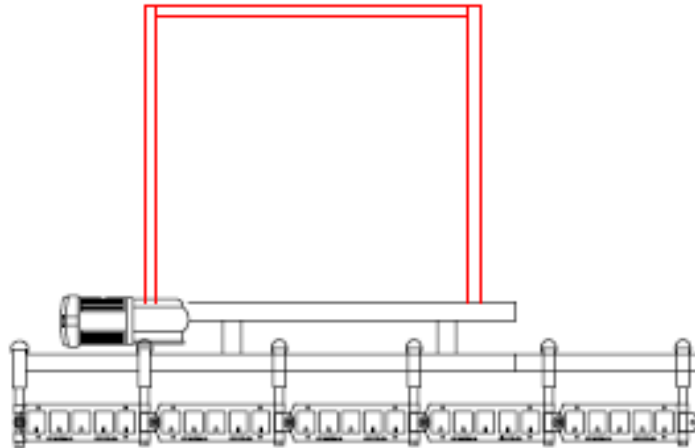

SIDE VIEW

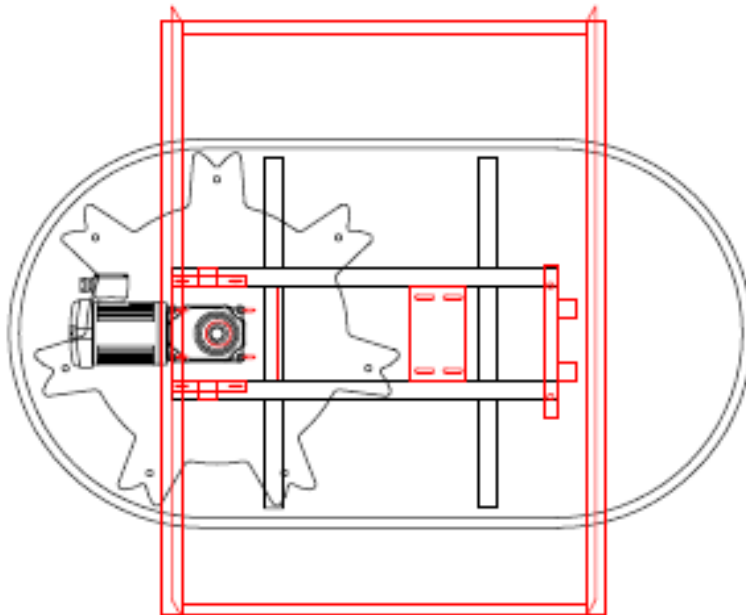

TOP VIEW

- STANDARD OVAL CONVEYOR
- SINGLE AND DOUBLE TIER CONVEYORS
 - ONE CEILING MOUNT 6' THROUGH 7'
 - TWO CEILING MOUNTS 8' THROUGH 10'
 - THREE CEILING MOUNTS 11' THROUGH 14'

TWO FLOOR SUPPORTS

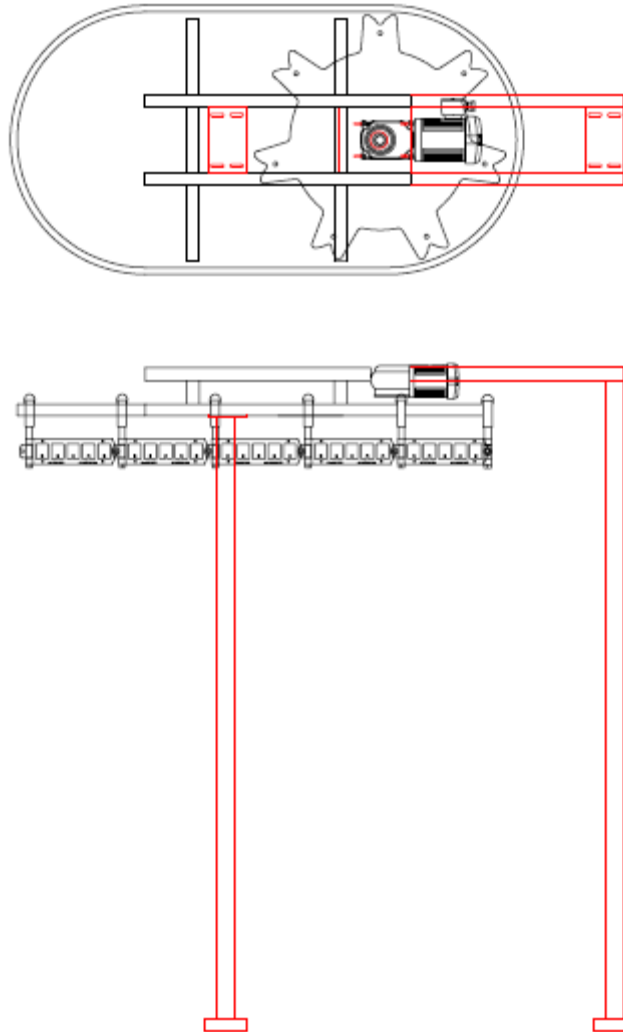

- STRAIGHT LINE AND DOUBLE-DECK CONVEYORS
 - ONE FLOOR SUPPORT INSIDE/ONE FLOOR SUPPORT OUTSIDE 6' AND 7'
 - TWO FLOOR SUPPORTS INSIDE CONVEYORS 7' THROUGH 12'
 - THREE FLOOR SUPPORTS CONVEYORS OVER 13'

TWO WALL MOUNTS

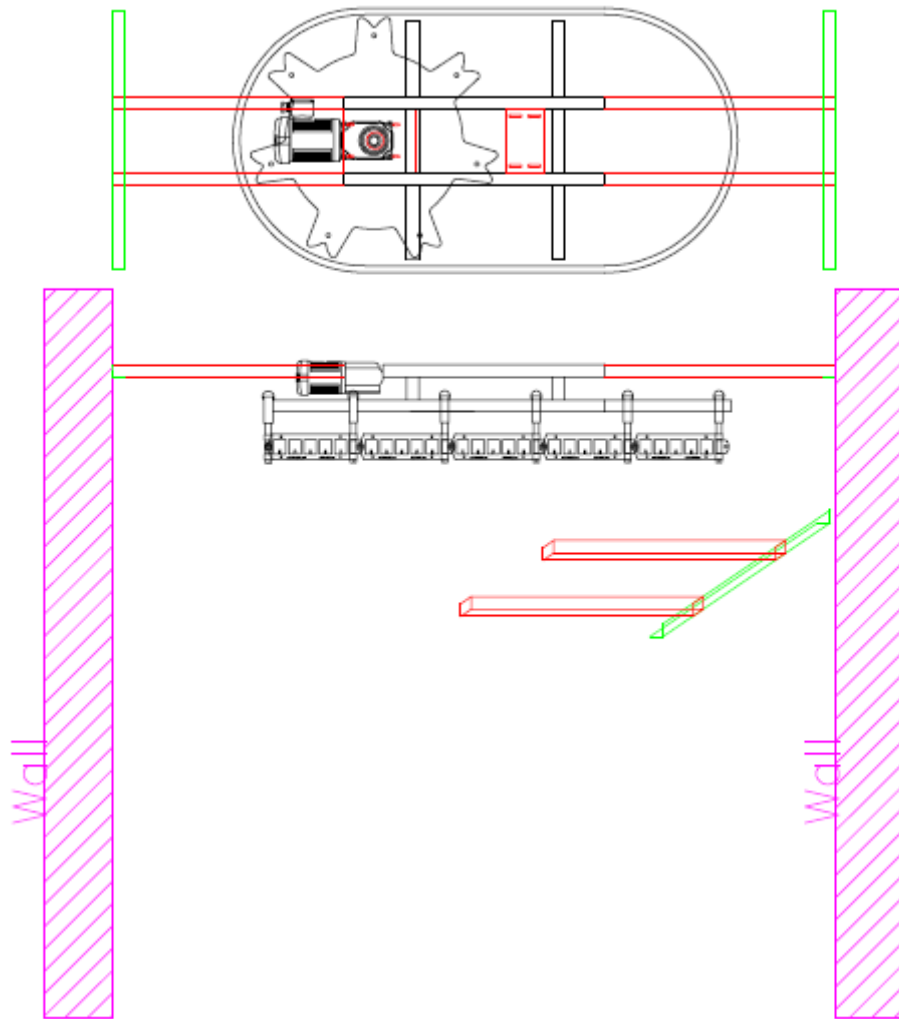

○ STRAIGHT LINE AND DOUBLE-DECK CONVEYORS 6' THROUGH 10'

FLOOR SUPPORT/WALL MOUNT

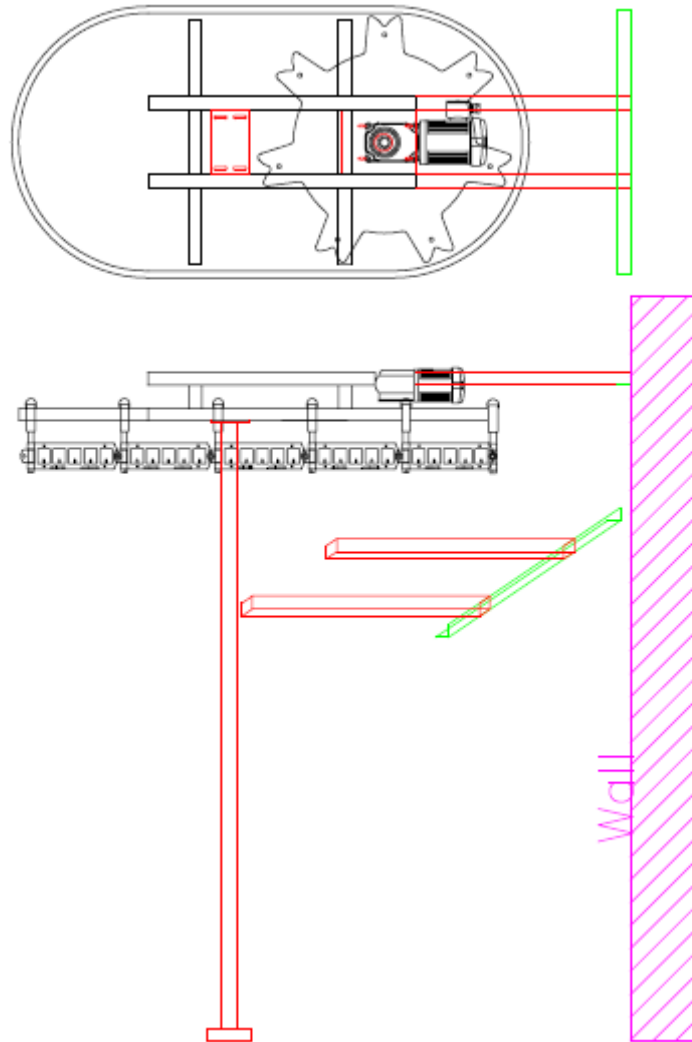

- STRAIGHT LINE CONVEYORS 6' THROUGH 10'
- CONVEYORS 10' THROUGH 14' REQUIRE ONE FLOOR SUPPORT/TWO WALL MOUNTS